

Equipment Family µP Automatic Burner Control MPA22

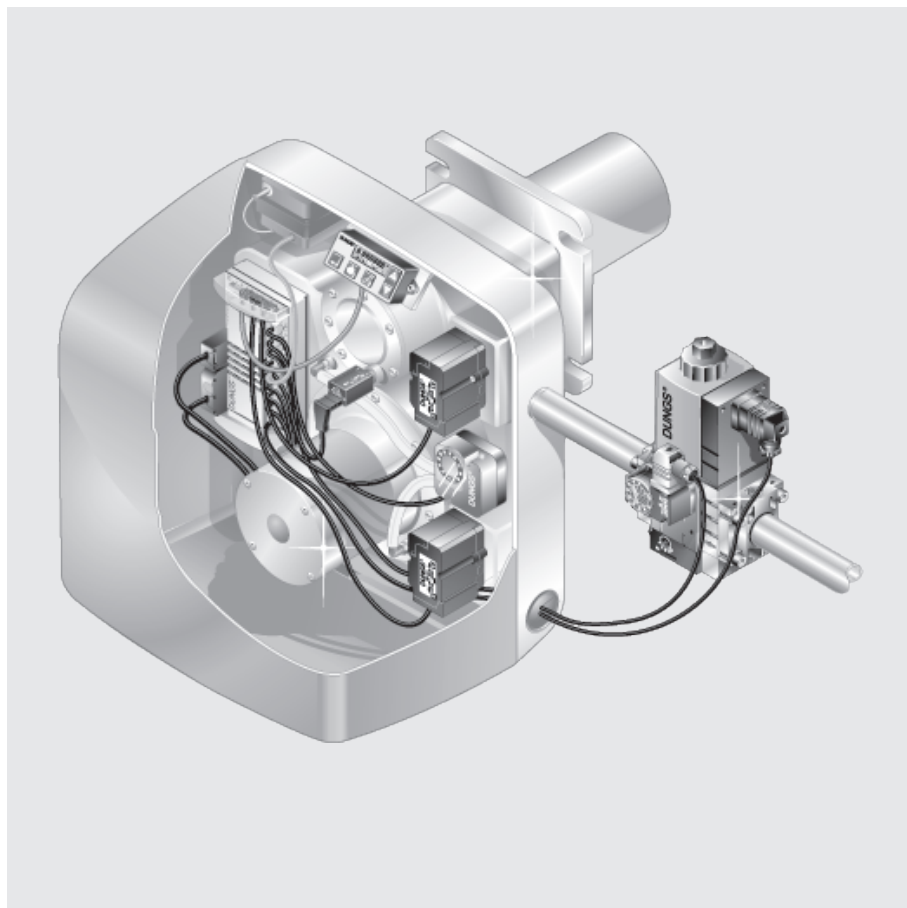

Automatic burner control for
gas and/or oil

1.01



Technical description

Microprocessor-controlled automatic burner control for intermittent operation for controlling and monitoring single-stage, two-stage and modulating blown burners with one or two electronically interlinked stepping motor actuator drives and an integrated valve proving system for operation as a gas burner control system.

Accessories

Flame monitoring device
Actuator drives
Display unit
eBUS interface
Plug set

Classification as per EN 298

FMCLJN, FMLLJN
The classification is dependent on the set-up.

Approvals

EU type test approval as per EU Gas Appliance Directive.

MPA22 CE-0085 AU 0316

EU type test approval as per EU Gas Appliance Directive.

MPA22 CE0036

Gas firing, electronic modulation

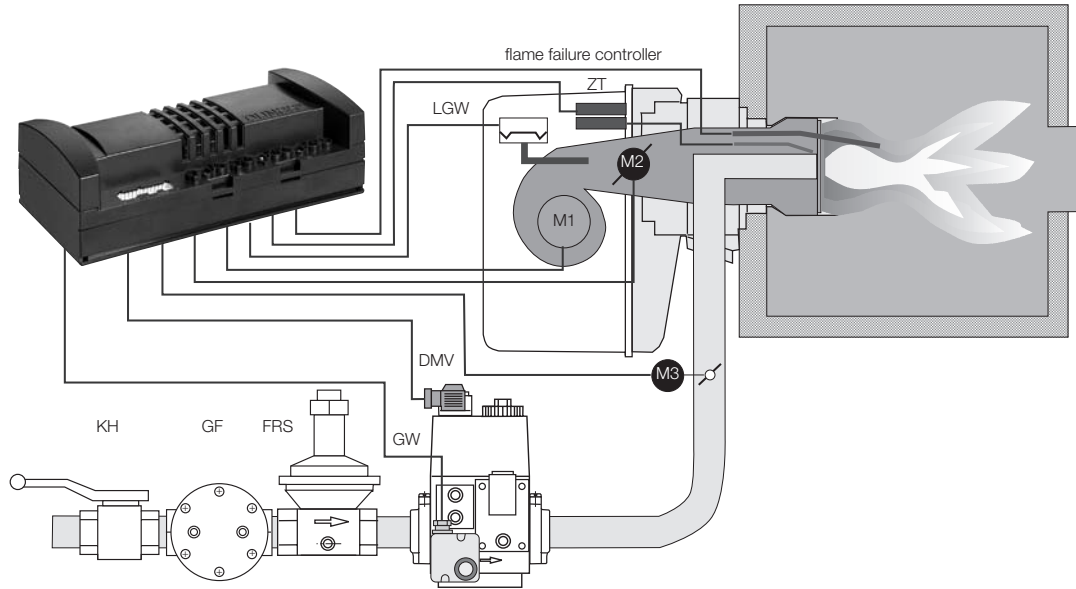

Terminal diagram

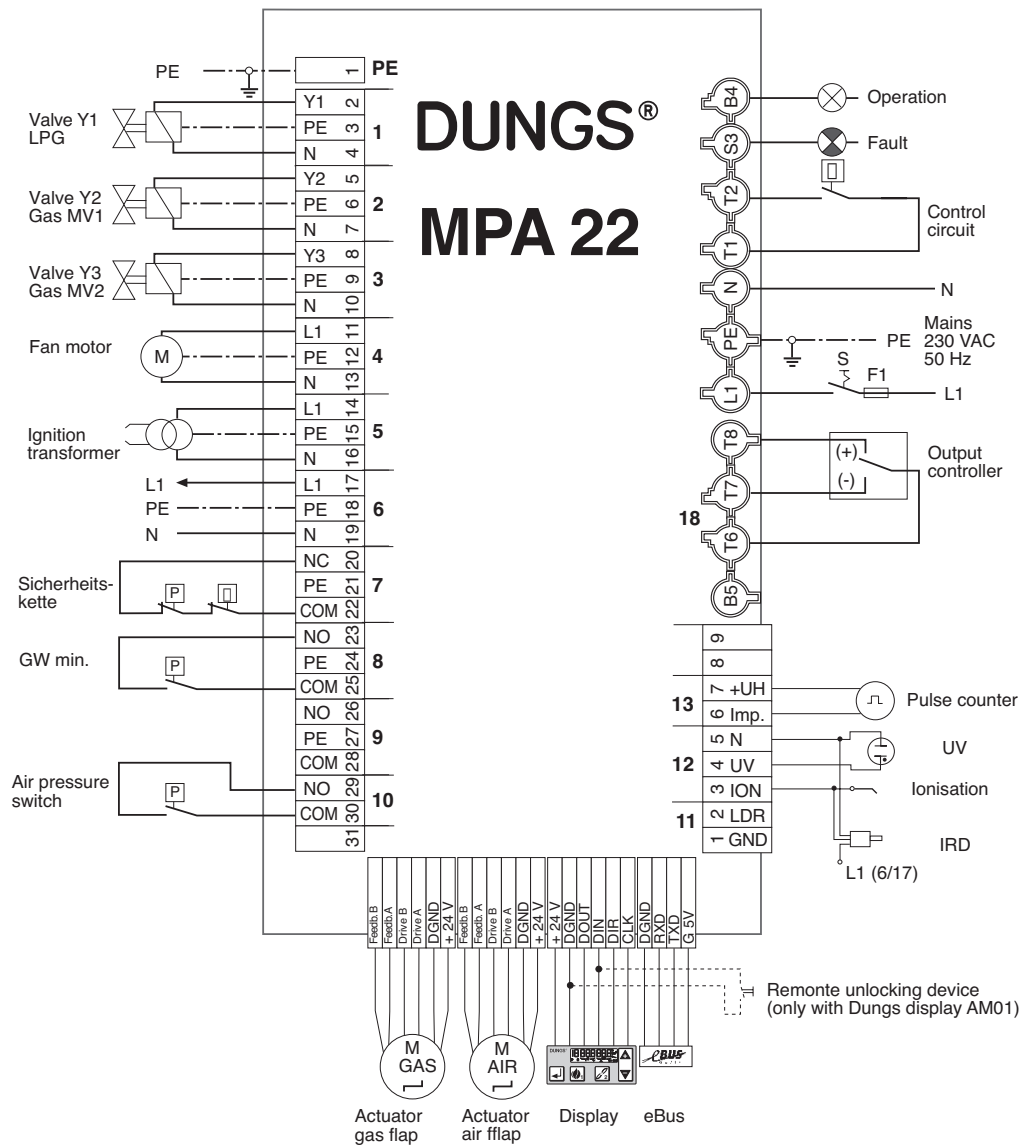

Gas firing, pneumatic modulation

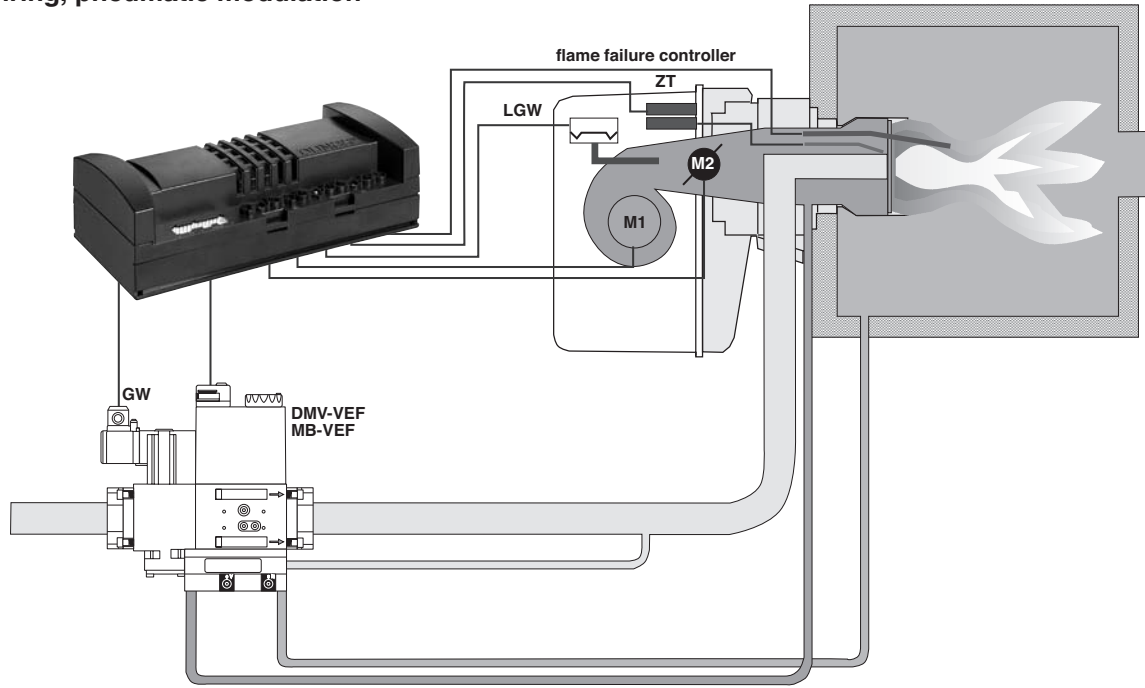

Terminal diagram

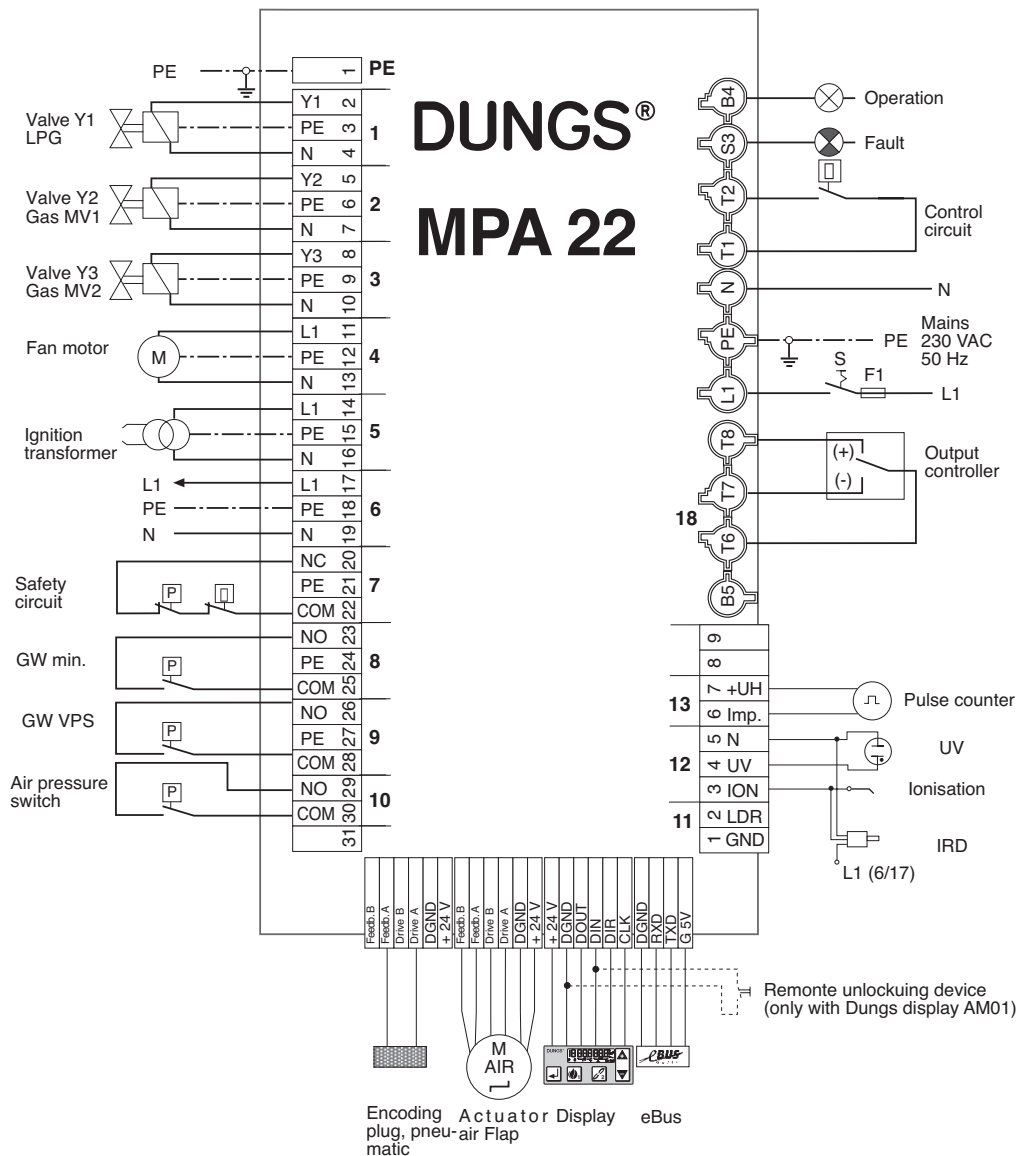

Oil firing, three stage

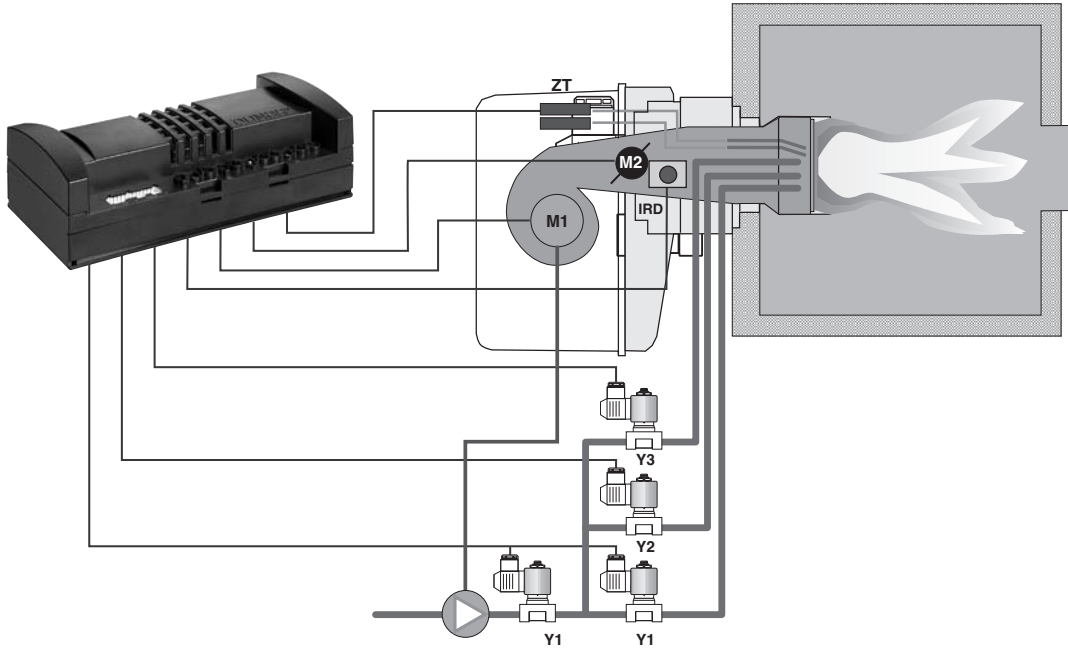

Terminal diagram

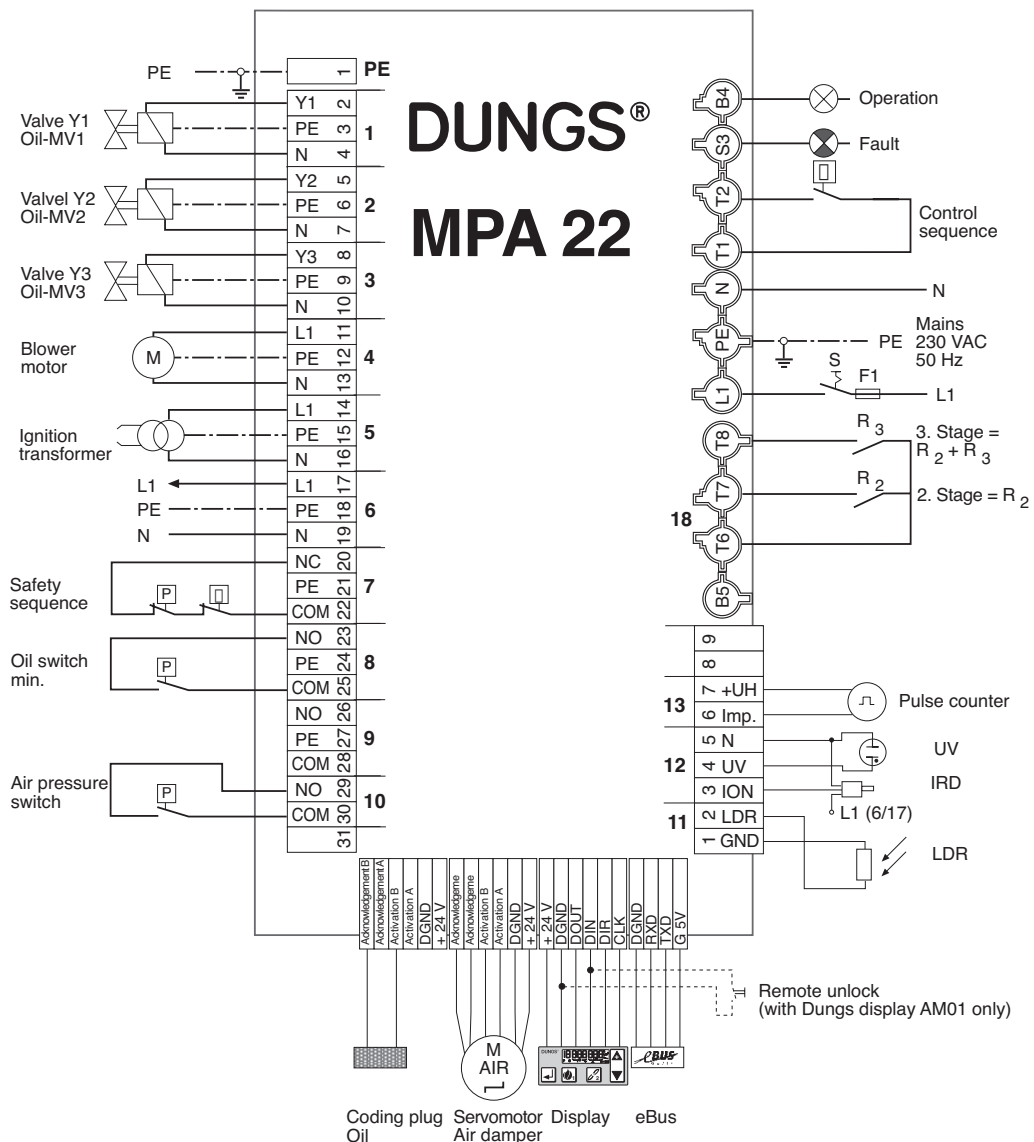

Display

The user-friendly display is used for the rapid adjustment of the complete MPA22 system.

During operation, various system information items are retrievable directly.

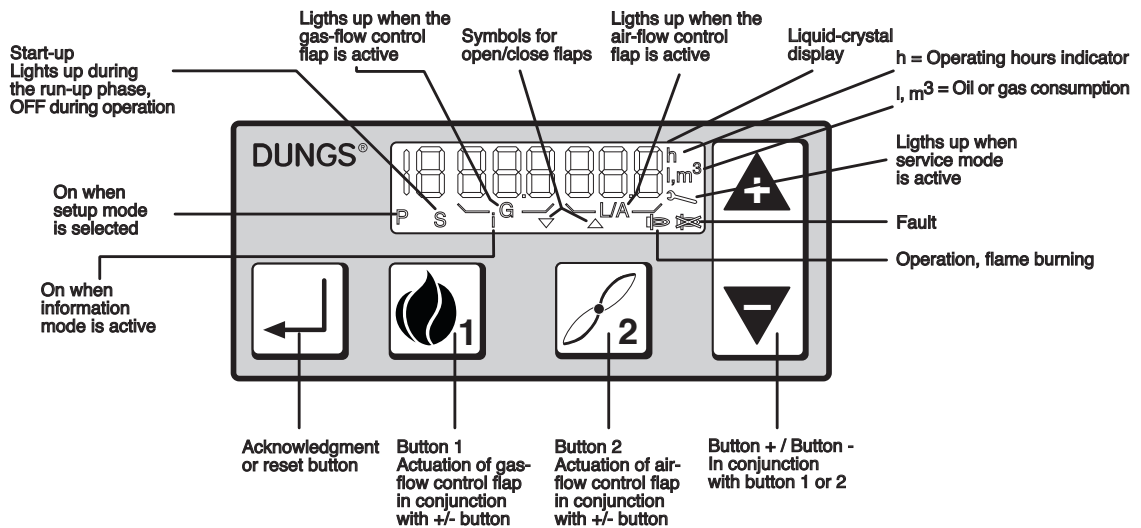

Parameter setting mode

In normal state the MPA22 is **always** in operating mode.

- State of the burner
- Display of the angle of the air flap in degrees
- Display of whether the stepping motors are in operation
- Count-down of the pre-ventilation time
- Display in the event of a gas deficiency
- Testing of the stepping motors on startup
- Display standby

Information mode

Information mode can be invoked during operating mode.

- Display of the fuel volume consumed
- Display of the operational hours
- Display of the quantity of successfully performed burner startups
- Display of the software version
- Display of the date the software version was written
- Display of the device number
- Display of the production date

Service mode

Service mode can be invoked during operating mode.

- State of the burner
- Display of the angle of the air flap in degrees
- Display of whether the stepping motors are in operation
- Count-down of the pre-ventilation time
- Display in the event of a gas deficiency
- Testing of the stepping motors on startup
- Display of why the burner is on standby at the moment
- Display modulation rate
- Display preset starting points
- Display controller enable time

Parameter setting mode

Parameter setting mode can be invoked only during standby and after the input of a **password**.

- Setting the eBUS address
- Setting the post-ventilation time
- Setting the waiting time
- Setting the pulse factor
- Setting the air flap position on standby
- Clearing the error memory
- Switching on and off the valve testing system
- Changing the valve testing times
- Switching on and off the failure controller function on an oil burner
- Change of direction of rotation
- Modulation speed reduction
- Setting the controller enable time

Setup mode

Setup mode can be reached only after the input of a **password**.

- Presetting the characteristic line when the burner is not burning
- Automatic calculation of the interpolation points
- In burning condition, correction of the gas and air points on the characteristic line and of the
- Setting the bottom limit (bu)
- Setting of the top limit (bo)

Error mode

Error mode is active only if the MPA22 has executed a **locking** procedure.

- Display of the error code
- By pressing the plus key other additional error codes can be called

Error mode can be quitted **only** by releasing the proce

Equipment features • applicable	MPA		
	Combined pneumatic control Gas/air	Combined electronic control Gas/air	2/3-stage operating mode Oil operation
System-specific fuel/air characteristic, variable	2 reference points 1 ignition point	9 reference points 1 ignition point	2-3 reference points 1 ignition point 1-2 changeover points
Number of actuator drives	1	2	1
Pre-ventilation period, variable	●	●	●
Post-ventilation period, variable	●	●	●
Pre-ignition period, variable	●	●	●
Stabilising time, variable	●	●	●
Safety periods, variable	●	●	●
Restarting	● ¹	● ¹	●
Integrated valve proving system	●	●	—
Variable valve proving times	●	●	—
Air damper actuator standby setting	●	●	●
External oil pump, connectable air pressure switch	—	—	●
eBUS interface	●	●	●
Variable eBUS interface address	●	●	●
Fuel quantity measurement via pulse input	●	●	●
¹ Recording of previous 6 error messages	●	●	●

¹ depending on application

We reserve the right to make any changes in the interest of technical progress.

Head offices and factory
 Karl Dungs GmbH & Co. KG
 Siemensstrasse 6-10
 D-73660 Urbach, Germany
 Telephone +49 (0)7181-804-0
 Telefax +49 (0)7181-804-166

Postal address
 Karl Dungs GmbH & Co. KG
 Postfach 12 29
 D-73602 Schorndorf, Germany
 e-mail info@dungs.com
 Internet www.dungs.com